



### INTRODUCTION

The focus and goal of the **Learn to Skate (L2S)** curriculums are designed to teach beginner hockey players the fundamentals of skating. Every association will have different needs, access to ice, a large variation in ages (4-10 years old) and number of players in their **L2S** sessions. If you have 5 or 60 new players, USA Hockey recommends that you use age and skill appropriate drills to teach the players how to skate and play hockey. It's important for these players to become comfortable on the ice, learn the basic hockey stance, stride, knee bend, use of edges and how to hold a stick before moving into a learn to play, 6U or 8U full hockey curriculum.

The **L2S1 Curriculum** consists of 4 practice plans for a total of 12 sessions and the **L2S2 Curriculum** consists of 4 practice plans plus two age appropriate FUN game days for a total of 14 sessions. USA Hockey recommends that each practice plan should be instructed 3 consecutive times before moving onto the next practice plan. Each practice consists of 6 different drills working on fundamental hockey skating skills. Most practice plans will have suggestions for advanced progression for those players who develop a little faster than others. Repetition and the appropriate progression for beginners are extremely important at this level. **Players should perform drills without a hockey stick during the L2S1 Curriculum, as this helps with the overall development of balance.**

**Before the first practice** have your coaches help these new players/families dress in all their hockey equipment. Spend 10 minutes off the ice in full gear teaching kids how to get up, stand in a hockey ready position, bend, touch toes, sit, squat, balance on one leg, etc. You will have kids sign up at various ages, athletic ability and confidence levels. Make sure you have some crates or skating walkers available for players who need that level of assistance. Assign a couple coaches to be in charge of these players.

**L2S practice plan template: Based on a 60 minute ice slot.**

**Free Time:** Let the players have the first five minutes of practice as FUN free play. Dump as many items from the bag of toys as possible onto the ice and let kids experiment. Younger players may be intimidated and scared the first 2-3 practices. During the first 3 sessions coaches should interact with their assigned group during the first 5 minutes to keep them active and engaged from the start.

**Length of Drills/Stations:** 5 drills x 8 minutes ending with an agility exercise to change the drill. Depending on the number of L2S players in your program all 5 drills may be instructed in the same 3rd or 6th of the ice for the entire 40 minutes. Have water accessible in each station or area.

**Coach to Player Ratio:** Recruit coaches, parents and student coaches to help run these practice sessions. Create more stations according to the total number of players. The more adults per players the smoother your practice will run and the more confident and safe the players will feel. A good ratio is 1 coach to 5 players. Coaches need to bring a lot of praise and enthusiasm to the L2S practices to encourage the young players!



## INTRODUCTION

**Agility:** Players perform an agility exercise 3-4 times before moving to the next activity. Examples: Drop to knees and get up, snow angles, superman, log rolls each direction, 2 foot jumps, etc. Select an agility exercise that the players can handle and progress from simple to complex over the length of the curriculum.

**Games:** Always play a ten minute game after completion of the 5 stations. Bubbles, Cut the Cake, Driving, Tag, Kick the Can, Red Light Green Light, Cops & Robbers, Clean Your Room, British Bulldog, Hand Ball Soccer, Score-O, etc.

**Free Time:** Let the players have the last five minutes of practice as FUN free play.

### Tools:

- Toy Bag: Ringette rings, soccer balls, nerf balls, softballs, tennis ball, small cones, bubbles, etc.
- Permanent Ice Markers.
- Skating Aids: Crates stacked on top of each other zip tied together, chairs, or ice skating walkers made out of PVC piping or metal.

PVC piping can be purchased at any hardware store.

### How to make PVC walker:

1 or 2 inch diameter, approximately 14 feet of piping needed.

### Cut into:

- 3: 22 inch pieces-2 Bottom Vertical and 1 Middle Pipe
- 2: 17 ¼ inch-Front Uprights
- 2: 15 inch- Bottom Horizontal
- 2: 8 inch-Top Vertical
- 2: 7.5 inch-Top Horizontal
- 8: 90 degree Elbows (4 on top & 4 on bottom)
- 2: Tee Connectors
- 22: Screws to reinforce each Elbow (2 each) and Tee Connectors (3 each)



METAL WALKER

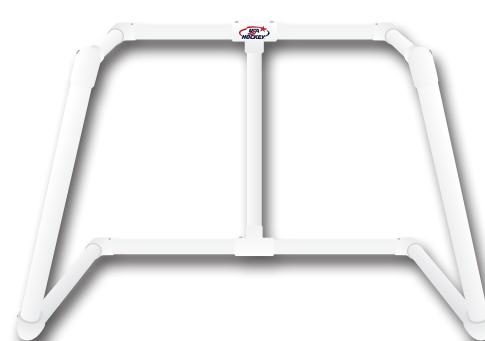

PVC PIPE WALKER

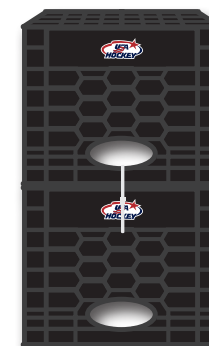

MILK CRATES



INTRODUCTION



**Skates:** The skates are the most important piece of gear. Make sure the skates fit right. The wrong fit will cause players frustration if too big and pain if too small.

**To Properly Fit Skates:**

1. Remove the insole from the skate and have the player stand on it. Make sure the heel is properly aligned with the heel of the insole. The big toe should almost reach the front edge of the insole. There should not be more than a 1/4 inch of insole showing.

**OR**

2. Loosen the laces of the skate and insert foot pushing toes up against the toe bed. No more than one finger should fit between the player's heel and the heel of the skate.

---

**Stick Length:** The stick is the next most important piece of equipment after skates.

Sticks need to be cut at the appropriate height for each player. Most kids have sticks that are too long. Have players stand in skates with stick on its end in front of player. Stick should be cut at chin level. It is important to buy the players a junior stick rather than an adult stick.

---

**Hammer Grip:** The top hand should hold the stick with a firm grip. Place the top hand so that the 'V' between the thumb and forefinger is on the top side of the stick and the shaft rests in the player's fingers like you would hold a **Hammer**.

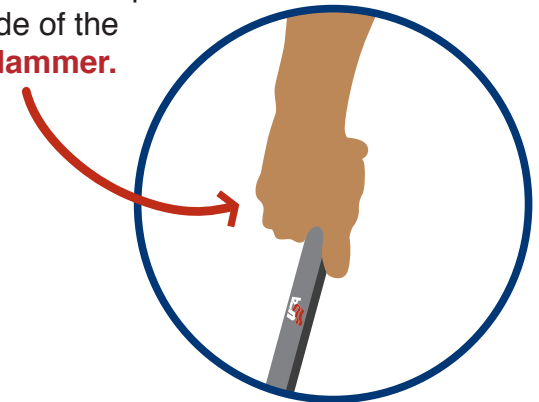



## STATION/DRILL 1: BACKWARD GLIDING & WALKING

8 MINUTES

Players line up facing boards without sticks in a basic **Backwards Hockey Stance**.

**Coaching Points:** Skating backwards is like sitting in a chair. Keep knees bent and back straight. Feet and knees are shoulder width apart. Lower center of gravity by keeping butt down. Keep head up, chest out and shoulders back. Weight is evenly distributed along skate blades.

**Part 1:** Without Stick put hands on boards and push body away from the boards and **Glide Backwards**. Repeat 4-5 times. Progress to **Pushing, Gliding, Squatting and Bobbing**.

**Part 2:** Using Stick have players face the boards. Assume **Basic Hockey Stance**. **Duck Walk** backwards to the blue line occasionally looking over right and left shoulder. Start with skates in a V position. Lift skates off the ice while shifting weight from one skate to another. Replace foot with toe turned outward each time. Return **Duck Walking** forward. Repeat.



BACKWARD GLIDING



HOCKEY STANCE

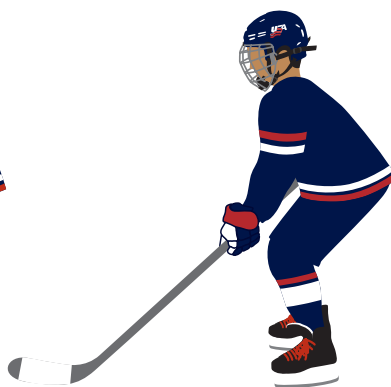

DUCK WALK

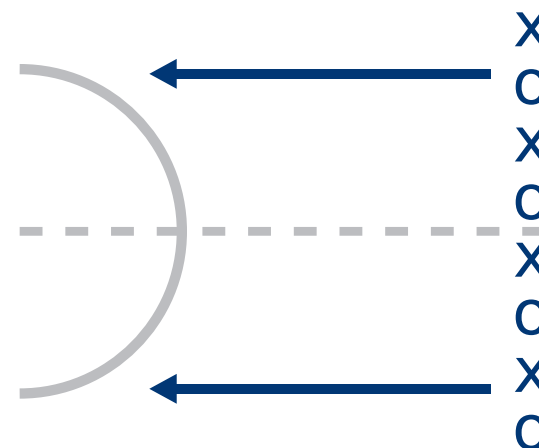



## STATION/DRILL 2: EDGES

8 MINUTES

**Glide Turns:** Set up a peanut with 6 cones. Coach draws pattern with an ice marker so it is easy for players to understand route. Players line up at cones 1 and 4. Players complete one and a half laps stopping at opposite line. Player skates forward and **Glides** on two skates around cones.

### Coaching Points:

- Skates are shoulder width apart, lead with inside skate
- Head and shoulders initiate turn
- Bend knees and lean in
- Weight on flat part of skate blade to ball of foot
- Lead with stick

The next player goes when first player reaches a cone. Change direction and repeat.

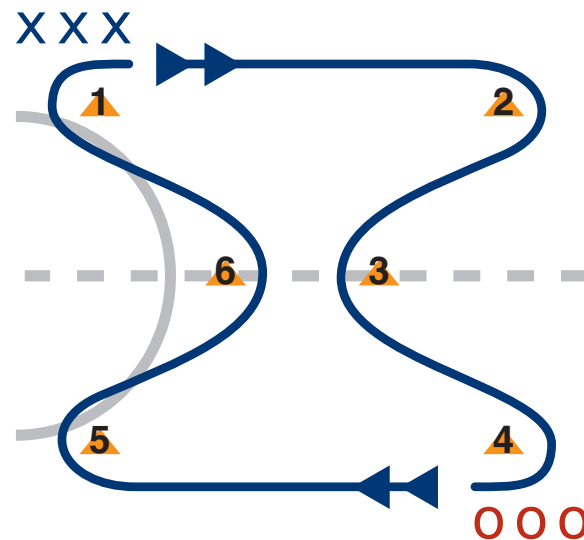



### STATION/DRILL 3: ABC's

8 MINUTES

**Relay Race:** Divide players into 2 teams. Lay sticks in suggested pattern. Perform Part 1 & Part 2 without sticks.

**Part 1:** Have players walk laterally over each stick, glide turn around cone, **Forward Stride** back to line tagging next player and ending with a **Snow Plow Stop** scraping off smiley face. Repeat facing opposite direction.

**Part 2:** Players step over sticks, **Glide Turn** around cone and **Forward Stride** back to line tagging next player ending with a **Snow Plow** stop scraping off smiley face.

**Part 3:** Players weave in and out of sticks, **Glide Turn** around cones **Forward Stride** back to line tagging next player ending with a **Snow Plow Stop** scraping off smiley face.

**Coaching Points:** Lead with stick on ice and inside skate. Make sure players do not drag toe around cone.

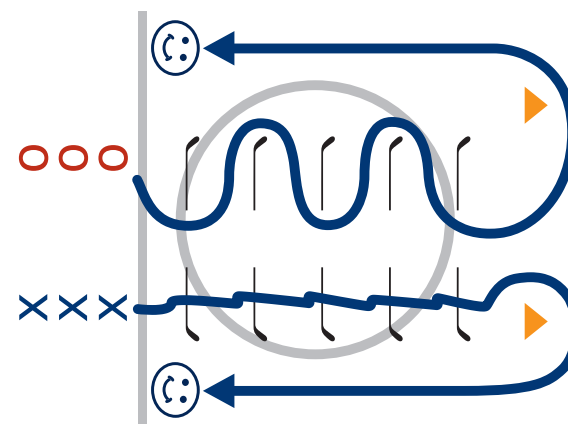

STEP OVER OBSTACLES



GLIDE TURN



1 FOOT SNOW PLOW STOP



## STATION/DRILL 4: PUCK HANDLING

8 MINUTES

*Players spread out in designated zone facing coach.*

**Stationary:** Have players pretend to stickhandle without a puck to emphasize wide stance, weight transfer and rolling of wrists. Players extend stick wide outside skates on forehand and backhand. Hold stance for 2-3 seconds to exaggerate weight transfer from left leg to right leg. After a few repetitions coach holds up a number of fingers and the players call out the number while **Stickhandling**.

**Coaching Points:** Players skates are parallel, a little wider than shoulder width. Toes are straight ahead, knees bent, chest up. Players transfer weight from left to right skate.

Top hand is control hand. Allow top hand to roll back and forth.  
Bottom hand grip is loose and guides stick. Hold stick like a hammer  
**(reference description in Introduction).**

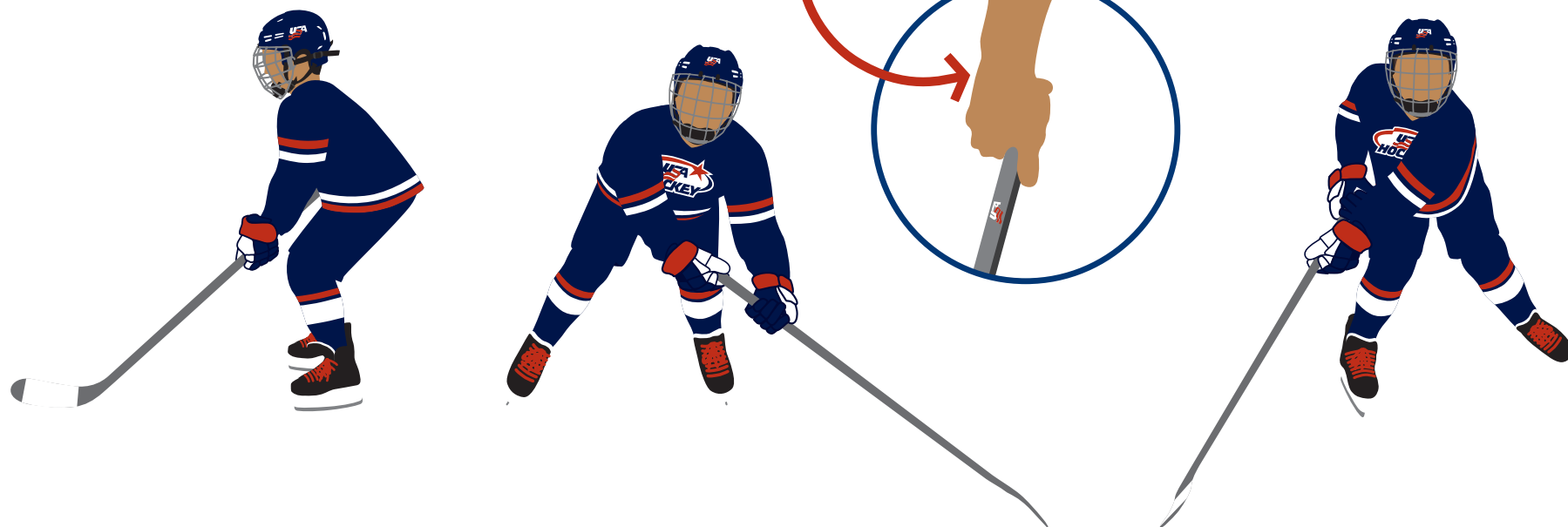
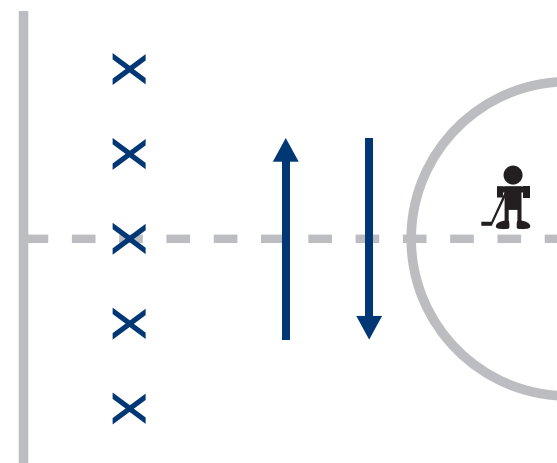



## STATION/DRILL 5: PUCK HANDLING & PASSING

8 MINUTES

**Passing:** Have players partner up and stand 15-20 feet apart.

**Stationary:** Player pass puck to partner, **Sweeping the Puck.** Partner receives puck and returns pass. *Repeat.*

### Coaching Points:

- Point shoulder at partner so players are passing across their body.
- Players stand in a **Hockey Stance** with a wide stance parallel to partner.
- Sweep puck behind back skate with puck on the heel of the stick blade.
- Body weight is on the back leg.
- Head is up looking at the target, make eye contact with receiver.
- Puck is passed with a sweeping action of the arms.
- Pull with the top hand and push with the bottom hand.
- Transfer weight from the back leg to the front leg. Follow through low and towards partner.

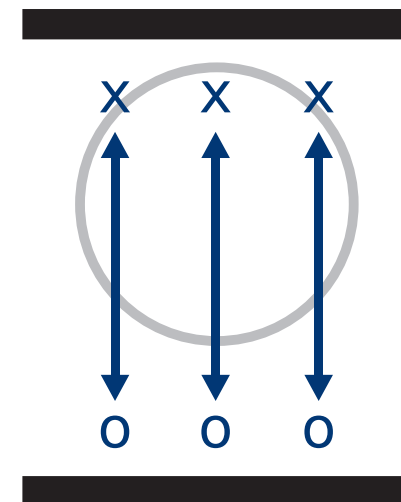
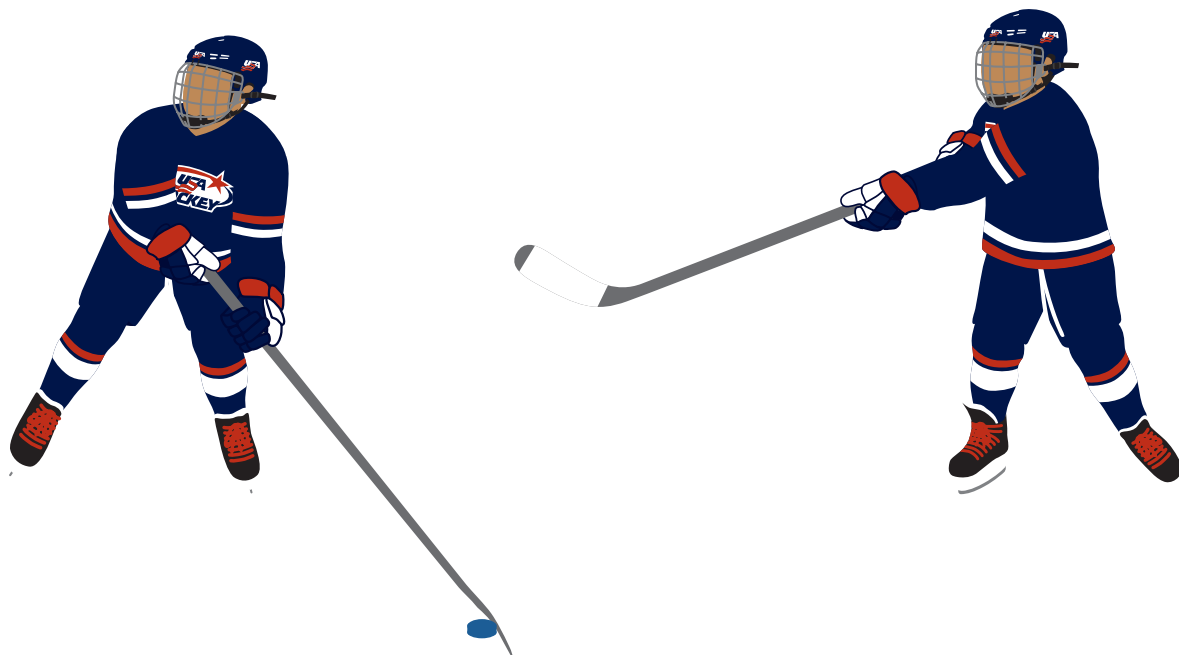



## GAME: KICK THE CAN

*Create 2 teams, and play without sticks.*

Use 2 soccer balls (cans) and play **3 v 3** or **4 v 4** with designated goals.  
Make sure kids bend their knees and use inside of foot while in kicking motion.

Rotate every 90 seconds.

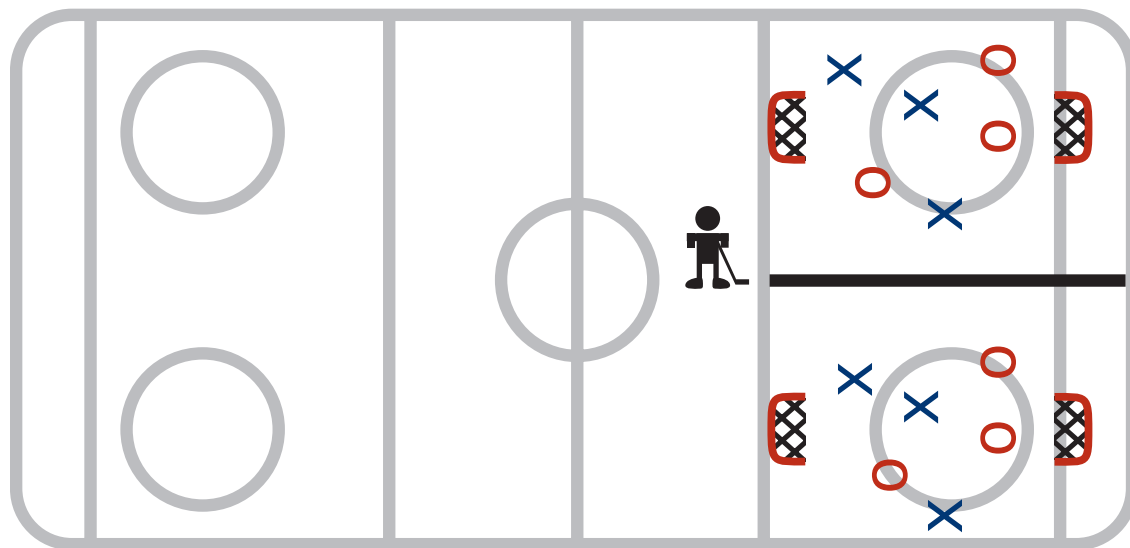



## STATION/DRILL 1: BACKWARD STANCE & BACKWARD WALKING

8 MINUTES

*Players stand on the goal line.*

**Coaching Points:** Skating backwards is like sitting in a chair. Keep knees bent and back straight. Feet and knees are shoulder width apart. Lower center of gravity by keeping butt down. Keep head up, chest up and shoulders back. Weight is evenly distributed along skate blades.

**Part 1:** Have players stand in basic backward hockey stance, then stand up straight, repeat 4 times. Have them drop to knees and get back into **Hockey Stance**.

**Part 2:** Have players face the boards. Assume **Basic Hockey Stance**. **Duck Walk** backwards to the blue line. Start with skates in a V position. Lift skates off the ice while shifting weight from one skate to another. Replace foot with toe turned outward each time. Return **Duck Walking** forward. Repeat.

**Part 3:** Perform **Fishes** (swizzles) backwards. Start with toes together using **Inside Edges**. Move heels outward, then inward until heels touch. Repeat creating **Fishes** backwards from goal line to blue line.



HOCKEY STANCE



DUCK WALK

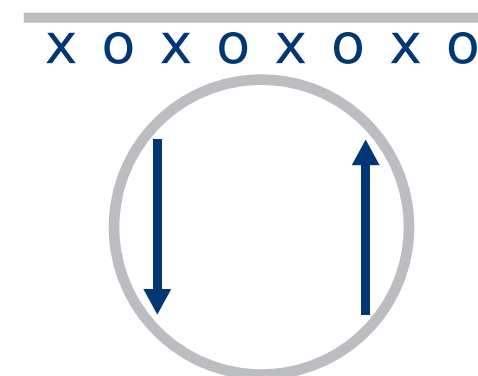



STATION/DRILL 2: FORWARD STRIDE/SKATING

8 MINUTES

**Coaching Points:** Begin in a **Hockey Stance**, knees bent with head and chest up. With weight on right leg turn left foot out slightly to the side, push down and to the side pressing the inside edge blade into the ice. Extend leg completely. Recover back leg to front leg aligning the knees back into a **Hockey Stance**.

**Forward Stride** alternating legs to blue line ending with a right foot **Snow Plow Stop**. **Forward Stride** back to goal line ending with a left foot **Snow Plow Stop**. Repeat.

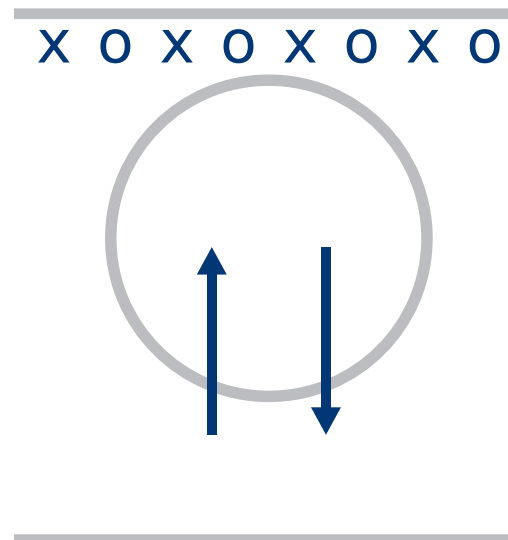



### STATION/DRILL 3: PUCK HANDLING

8 MINUTES

*Each player has a blue puck.*

**Stickhandle** the puck from the left side to right side in front of body. Hold puck for 2-3 seconds to help exaggerate weight transfer from left leg to right leg. Alternate between narrow (inside skates) and wide dribbles (outside skates). After a few repetitions coach holds up a number of fingers and players call out the number while **Stickhandling**.

Players skate from goal line to blue line **Stickhandling** side to side. On command have them stop where they are and stationary **Stickhandle** narrow and wide in front of their body.

**Coaching Points:** Top hand is control hand. Allow top hand to roll back and forth. Bottom hand grip is loose and guides stick. Hold stick like a hammer (reference description in Introduction).

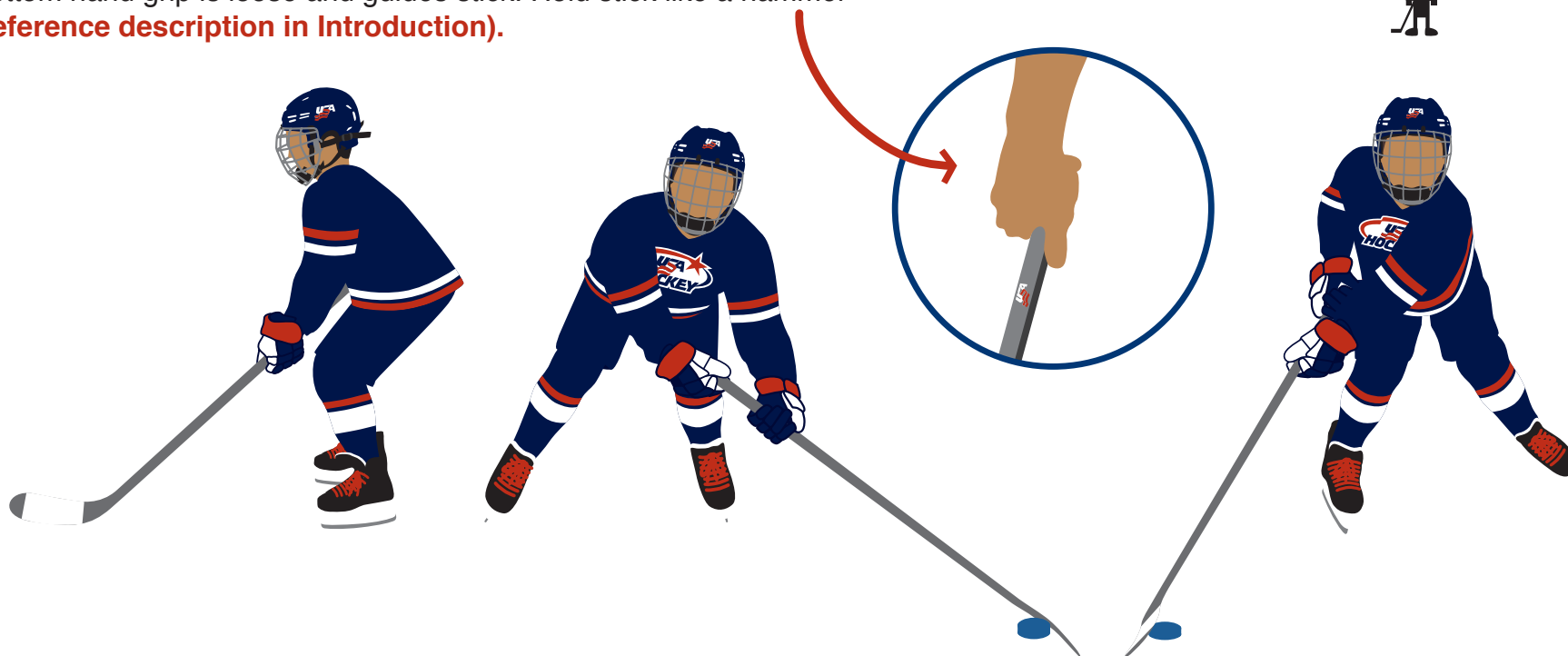
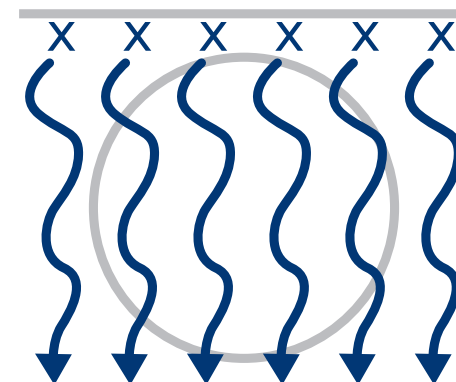



## STATION/DRILL 4: SWEEP PASS

8 MINUTES

**Sweep Pass:** *Players partner up, stand 8-10' apart and pass a blue puck back and forth.*

**Work on proper technique:** *Emphasize keeping the hands away from the body and **Sweeping the Puck.***

### Coaching Points:

- Point shoulder at partner so players are passing across their body.
- Start puck behind back skate with puck on the heel of the stick blade.
- Body weight is on the back leg.
- Head is up looking at the target, make eye contact with receiver.
- Puck is passed with a sweeping action of the arms.
- Pull with the top hand and push with the bottom hand.
- Transfer weight from the back leg to the front leg. Follow through low and towards partner.

**Scatter Puck Game:** All players have a blue puck. Divide the players into 2 teams. Each team must stay on their designated half of the ice. For 30 seconds players shoot pucks to the other team's side of the ice. Team with the least number of pucks on their side when time runs out wins. Repeat several times.

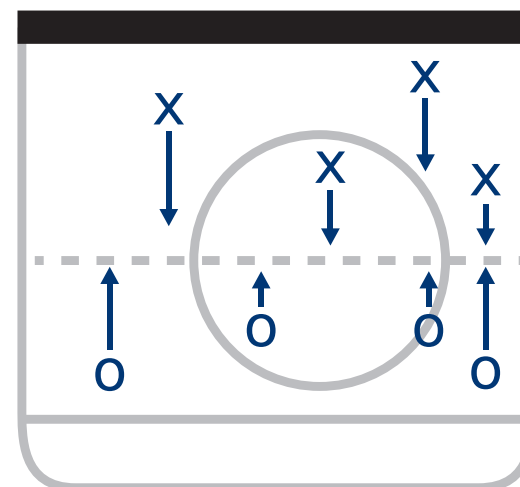
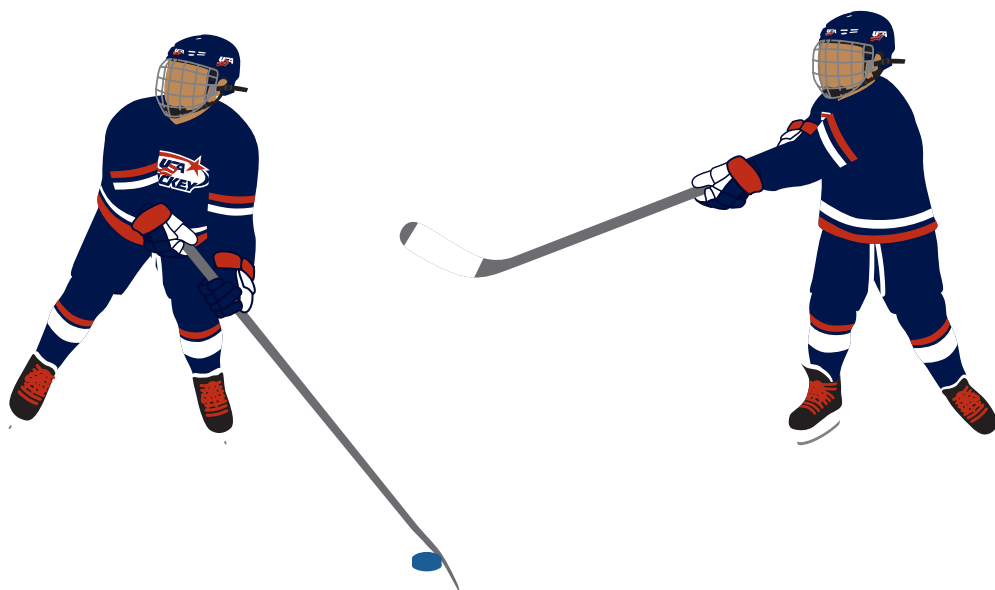



## STATION/DRILL 5: FORWARD C-CUTS

8 MINUTES

Coach draws a “C” on the ice with a ice marker. Players place hands on boards shoulder width apart.

Players practice making **C-Cuts** with both skates by tracing the “C.”

**Coaching Points:** Progress to starting in the hockey stance position, point left toe outward with heel touching right heel to form an L shape. Shift weight to right side, and push away with left skate by using a **C-Cut**. Point toe back in and return skate to start position. Repeat.

Progress to moving **C-Cuts**. Starting in the **Hockey Stance** position players skate goal line to blue line performing **C-Cuts** with left foot and return using right foot.

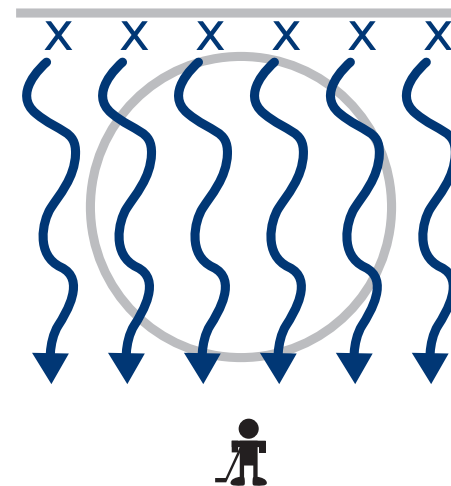



GAME: RED LIGHT GREEN LIGHT

10 MINUTES

*Players start on side boards.*

Players skate towards center ice where the policeman (coach) is holding a red painted puck and a green painted puck. Coach can also use a crossing guard sign.

If coach holds up a red painted puck player must stop moving - working on **Snow Plow Stops**. Return to side boards and start again.

If player is caught moving on a **Red Light** they must return to start. First player to policeman (coach) is the winner.

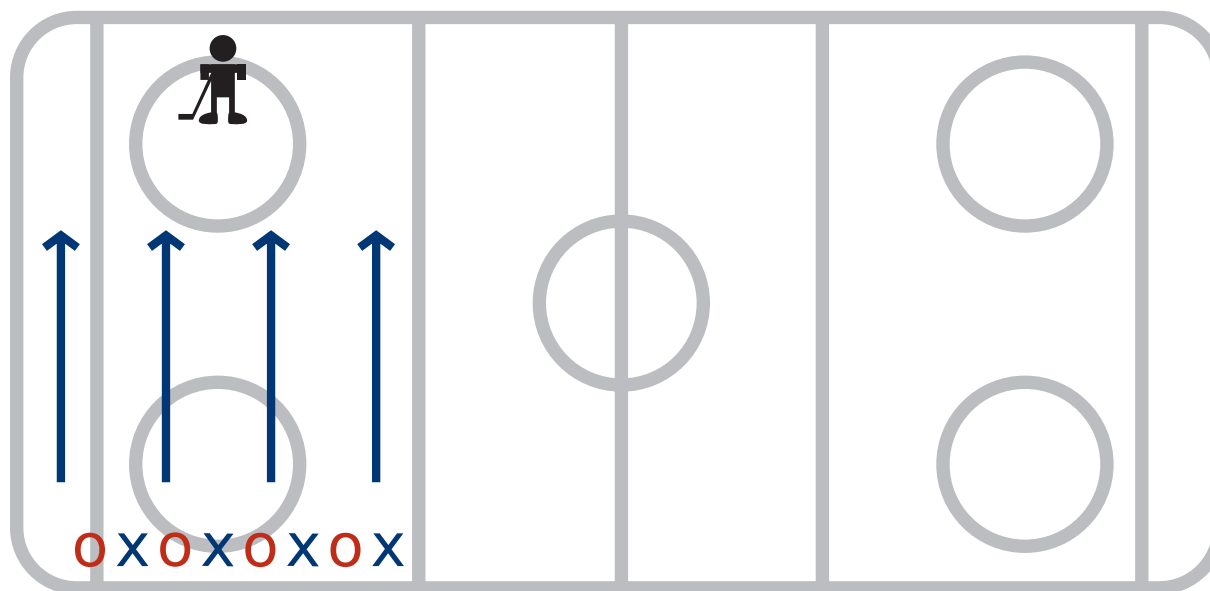



## STATION/DRILL 1: ABC'S & EDGE WORK

8 MINUTES

*Divide players into 2 lines if you have more than 6 players.*

Players weave in and out of cones, **Snow Plow Stop** touch side boards, continue to skate around 2 remaining cones, step in and out of each tire skating back into line. When player reaches the 3rd cone the next player goes. This allows 3 players from each team to be involved at the same time.

**Relay Race:** Perform drill as a race. Second player may leave once first player touches the side boards and third player goes when first player tags them.



GLIDE TURNS



1 FOOT SNOW PLOW

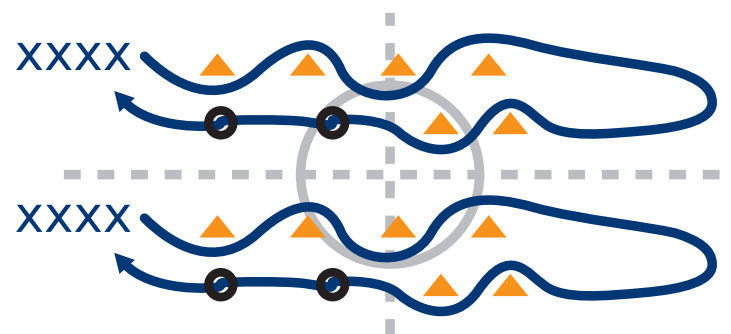



## STATION/DRILL 2: SWEEP SHOT

8 MINUTES

*Each player has a blue puck and lines up 8-10 feet from the boards.*

**Coaching Points:** Bring puck behind body with puck on heel of stick. Begin with weight on the back leg. **Sweep the Puck** forward transferring weight to front leg and rolling over wrists.

Players repeat **Sweep Shots** against boards.

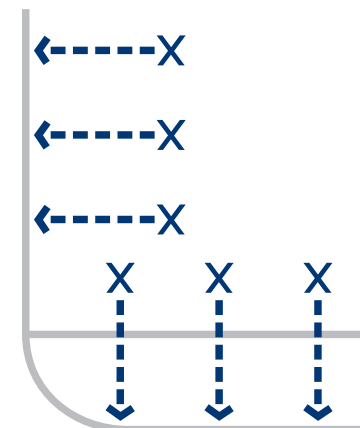
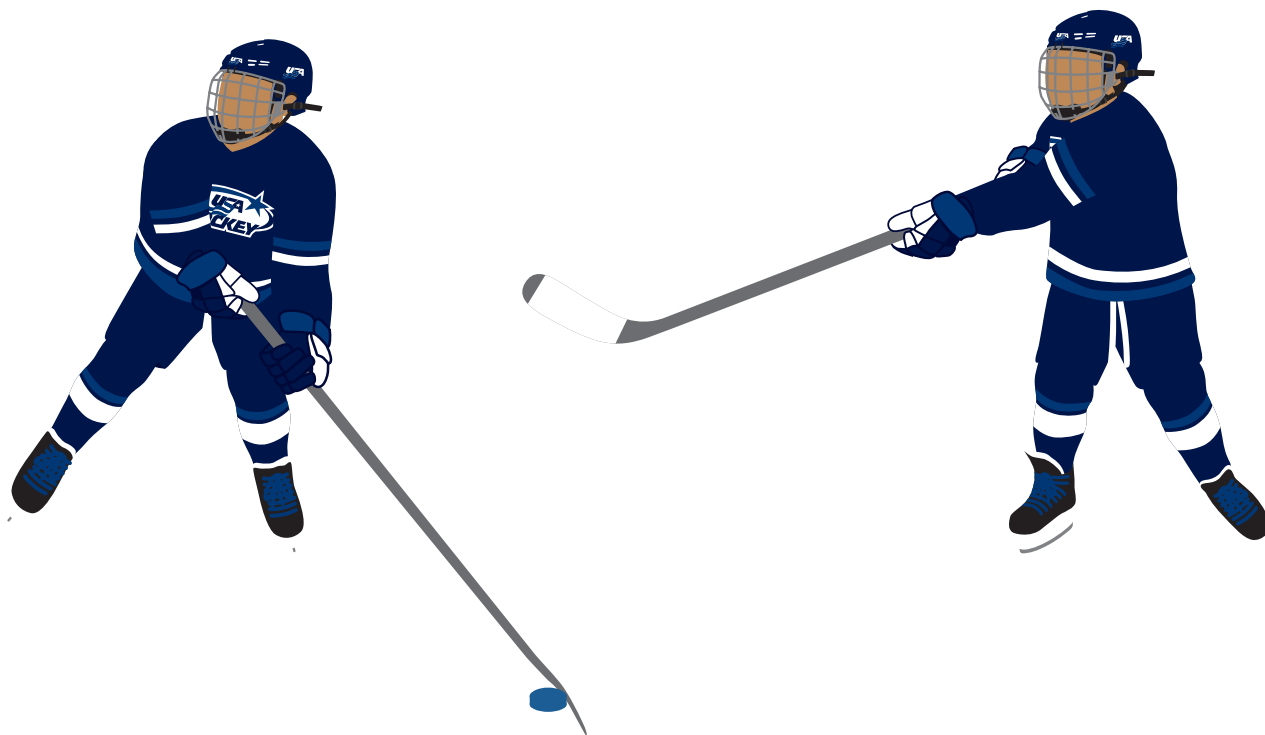



### STATION/DRILL 3: BACKWARD C-CUTS

8 MINUTES

Coach draws a "C" on the ice with a ice marker.  
Players place hands on boards shoulder width apart.

Players practice making **Backward C-Cuts** with both skates by tracing the "C."

**Coaching Points:** Progress to moving C-Cuts. Starting in the **Hockey Stance** position, point left heel outward, shift weight to right side, and push away with left skate by using a **C-Cut**. After extension, point heel back in and return skate to start position. Begin on the flat part of the skate blade and finish extension with the toe. Repeat.

Have players skate goal line to blue line **Backward C-Cutting** with left foot and return using right foot.

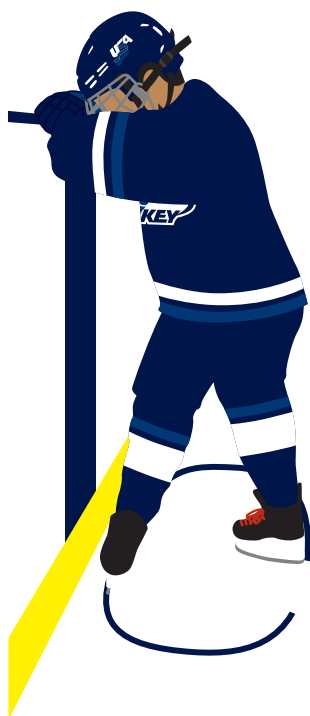
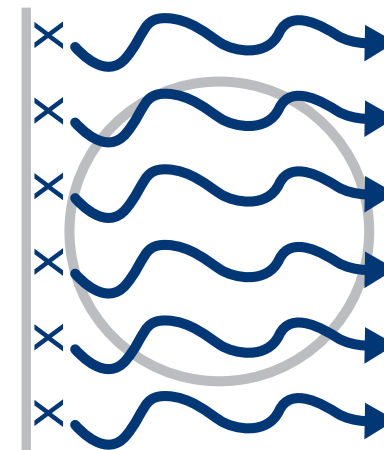



### STATION/DRILL 4: ABC's

8 MINUTES

**Obstacle Course:** Coach uses a ice marker to draw course. Players place sticks along boards and start drill lying on their back with feet facing coach.

Player performs continuous **Log Rolls** left to the first cone. Get up and **Superman** between the cones, **Skate** around first tire, **Jump/Step** over hockey sticks, **Skate** around second tire, fall to knees then **Get Up** and **Skate** back into line and repeat.

Half way through station time move line to start on opposite side to **Log Roll** and **Skate** around tires the other direction. A minimum of six players should be active during the drill.

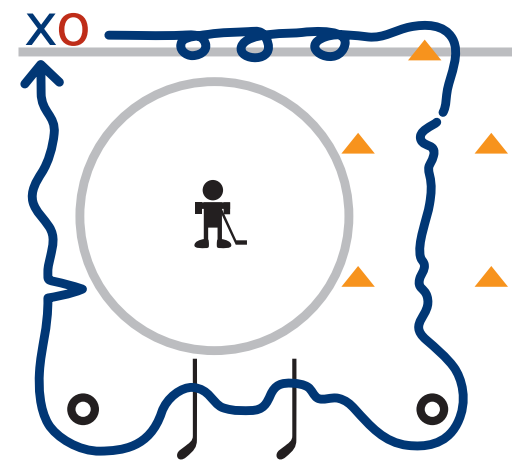

LOG ROLL

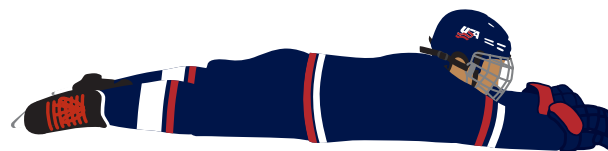

SUPERMAN

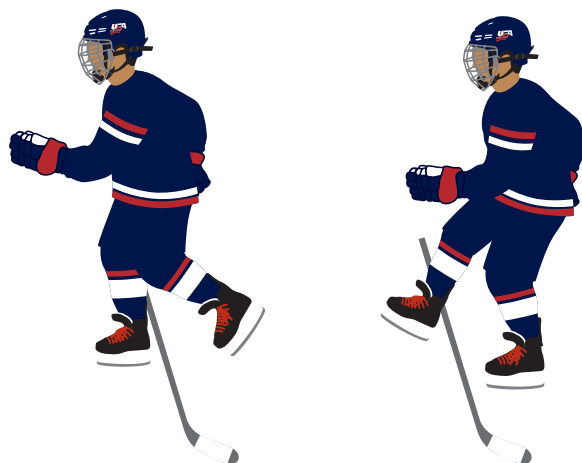

STEP OVER OBSTACLES



GETTING UP





## STATION/DRILL 5: EDGE WORK, STOPS & PUCK HANDLING

8 MINUTES

**Obstacle Course:** Coach sets up 6 cones in a peanut formation. Coach uses an ice marker to draw pattern ending with an X.

Players skate pattern around cones performing **Glide Turns** finishing with a **Snow Plow Stop**. Have players try to build a pile of snow to cover the "X."

**Coaching Points: Glide Turns:** Make sure stick is on the ice leading players around each cone. Teach players to lean into cone. Skate closest to cone should be the lead foot. Correct players if they drag the inside foot.

**Advanced:** Puck handle blue pucks around obstacle course.

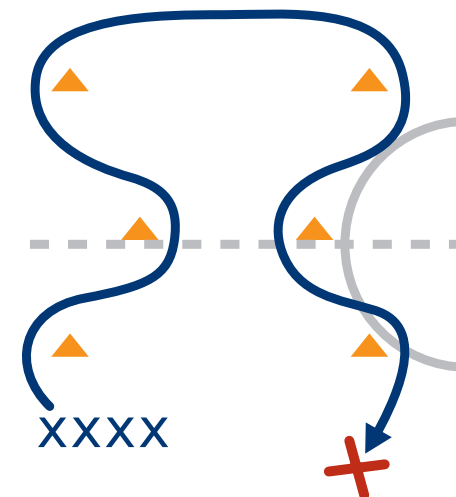

GLIDE TURNS



1 FOOT SNOW PLOW

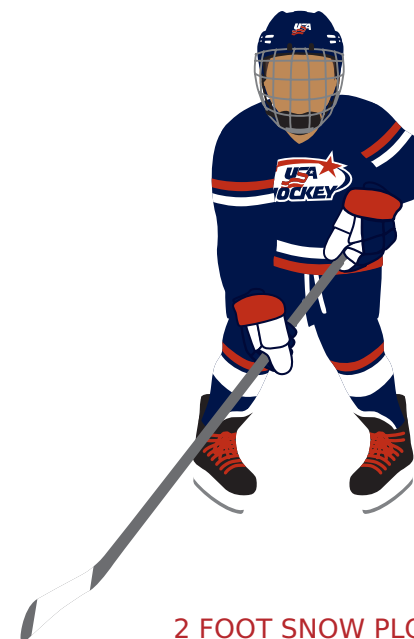

2 FOOT SNOW PLOW



GAME: SCORE-O

10 MINUTES

All the pucks are scattered in the neutral zone. Divide players into 2 teams. Each team starts on their blue line. Use one third of ice surface to play **Score-O**.

On whistle each team tries to get as many pucks as they can onto the other team's nets. Players are allowed to steal pucks from the other team and out of their own net.

Team with the most goals after 3 minutes wins. Repeat.

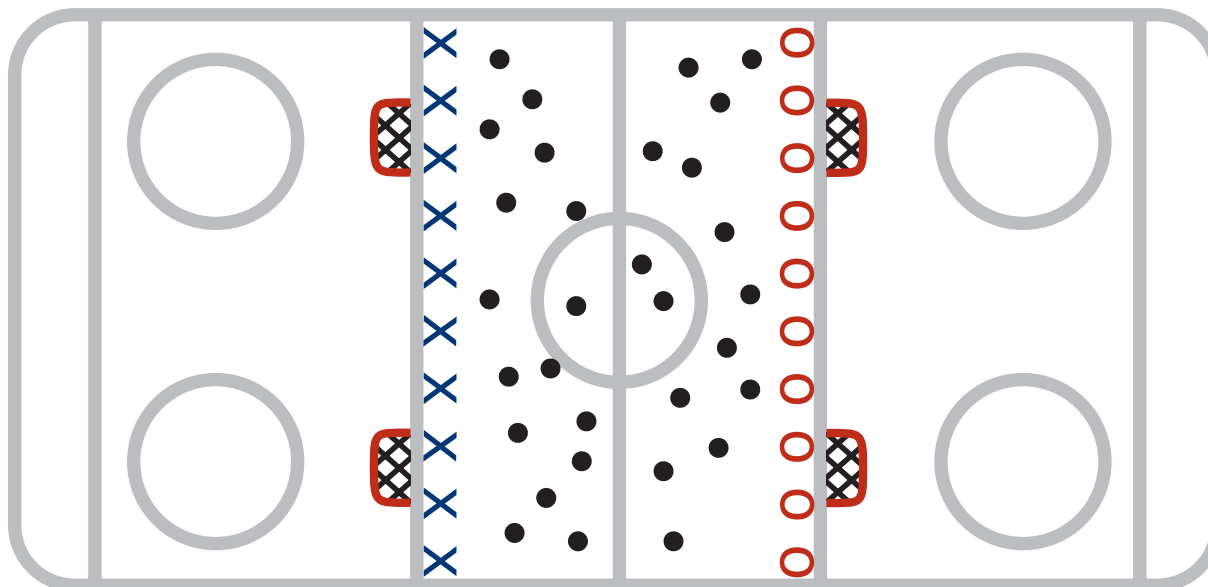

**Glide Turns:** Set up a peanut with 6 cones. Coach draws pattern with an ice marker so it is easy for players to understand route. Players line up at cones 1 and 4. Player skates forward and **Glides** on two skates around cones.

**Coaches Points:**

- Skates are shoulder width apart, lead with inside skate
- Head and shoulders initiate turn
- Bend knees and lean in
- Weight on flat part of skate blade to ball of foot
- Lead with stick

The next player goes when first player reaches a cone. Change direction and repeat.

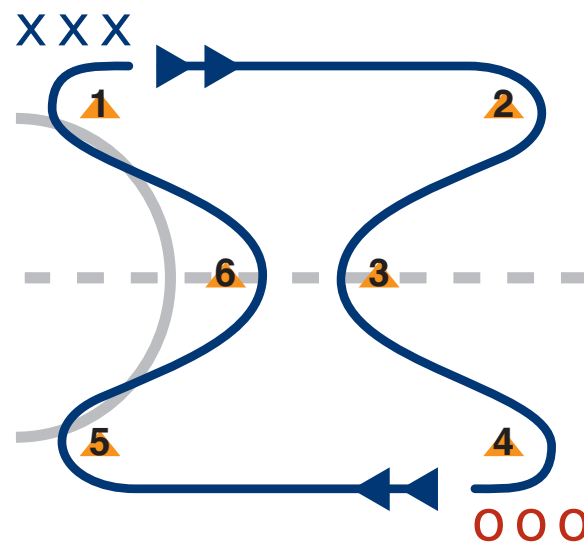



## STATION/DRILL 2: PUCK HANDLING

8 MINUTES

*Each player has a puck.*

**Part 1: Stickhandle the Puck** from the left side to right side in front of body. Hold puck for 2-3 seconds to help exaggerate weight transfer from left leg to right leg. Alternate between narrow (inside skates) and wide dribble (outside skates). After a few repetitions coach holds up a number of fingers and players call out the number while **Stickhandling**.

**Part 2:** One group skates and **Stickhandles** a puck inside circle while the other group skates and **Stickhandles** a puck outside circle but inside designated station area. *On command players switch roles.*

**Coaching Points:** Players skates are parallel, a little wider than shoulder width. Toes are straight ahead, knees bent, chest up. Players transfer weight from left to right skate.

Top hand is control hand. Allow top hand to roll back and forth. Bottom grip is loose and guides stick. Hold stick like a Hammer (**reference description in Introduction**).

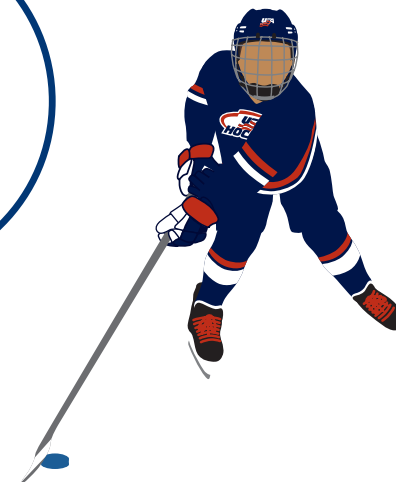
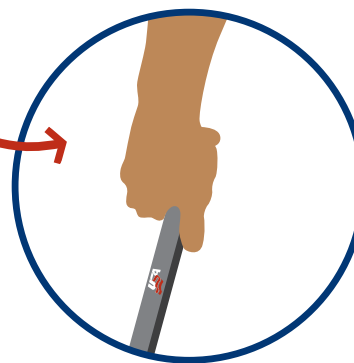
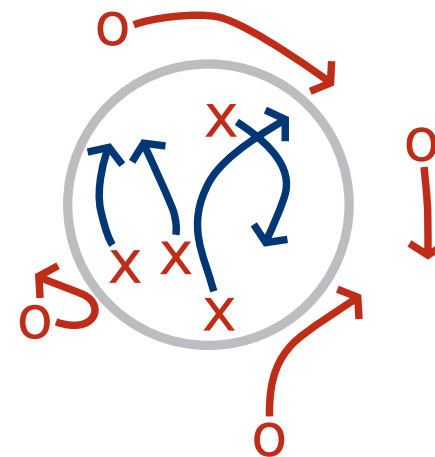



### STATION/DRILL 3: INSIDE EDGES

8 MINUTES

**Swizzles:** Begin from **Hockey Stance** position. Put heels together to form a V position. Using **Inside Edges**, push toes outward, then toes inward making toes touch. Make the shape of a **Fish**. Repeat creating **Fishes** forward from goal line to blue line. Player should remain in hockey stance with stick on the ice.

Perform **Fishes** backwards. Starts with toes together using **Inside Edges** move heels outward, then inward until heels touch.

Repeat creating **Fishes** backward from goal line to blue line.

**Rocking Horse:** Perform one **Fish** forward then one **Fish** backwards. Create **Fishes** around 5 small cones, skate hard around cone and return to line. Repeat.

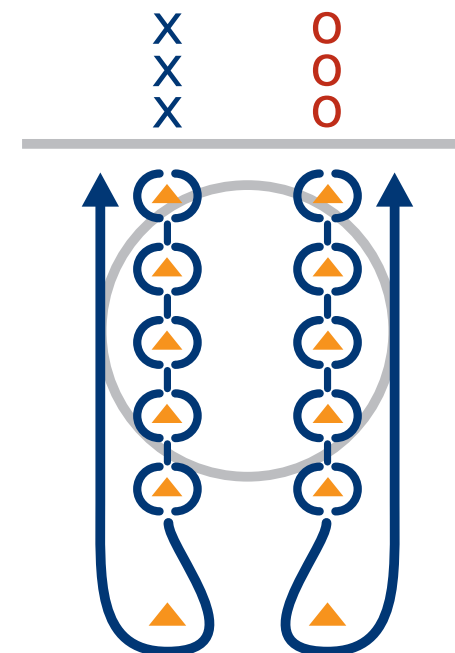
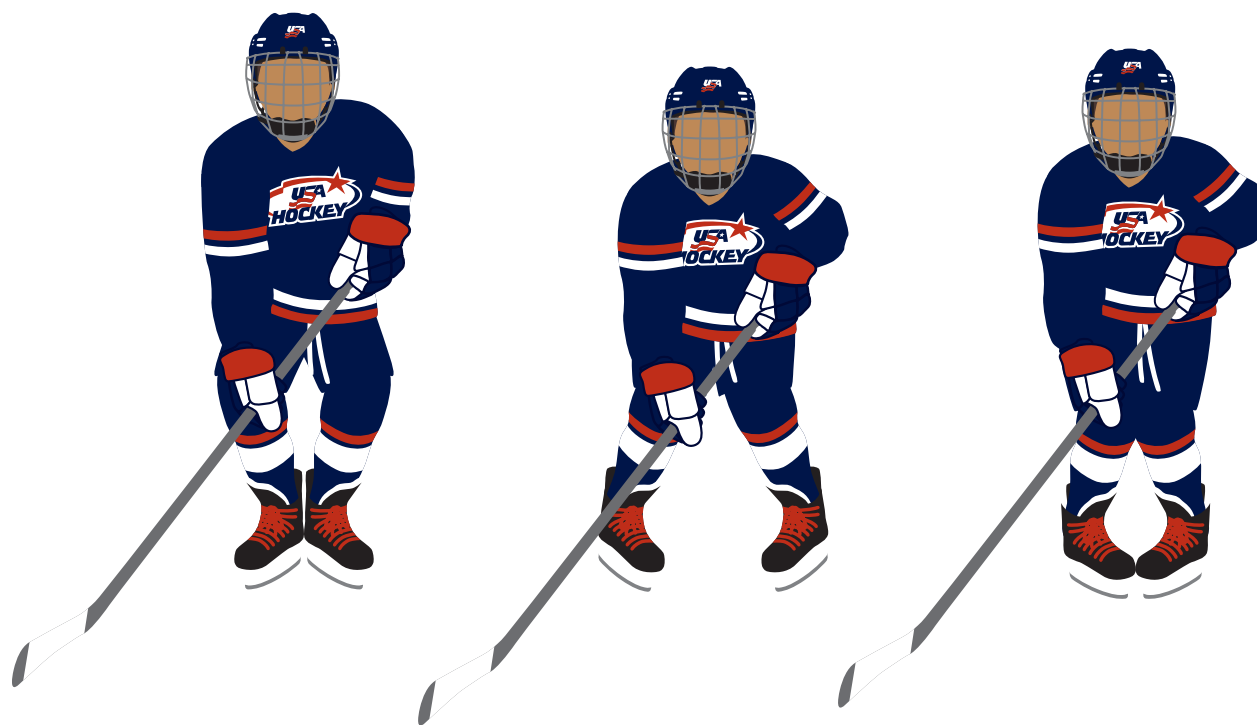



### STATION/DRILL 4: ABC's

8 MINUTES

**Relay Race:** Divide players into 2 teams. Lay sticks in suggested pattern.

**Part 1:** Players step over sticks, **Glide Turn** around cone and **Forward Stride** back to line tagging next player ending with a **Snow Plow** stop. Perform without sticks.

**Part 2:** Players weave in and out of sticks, **Glide Turn** around cones skating back to line tagging next player ending with a **Snow Plow** stop. Players snow plow stop scraping off smiley face.

**Coaching Points:** Lead with stick on ice and inside skate. Make sure players **do not** drag toe around cone.

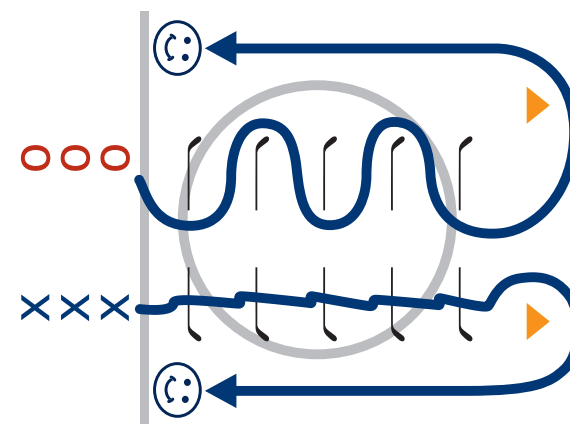

STEP OVER OBSTACLES



GLIDE TURN



1 FOOT SNOW PLOW



STATION/DRILL 5: ABC'S, EDGE WORK, PUCKHANDLING

8 MINUTES

*Divide players into 2 lines if you have more than 6 players.*

Players weave in and out of cones, **Snow Plow Stop** touch side boards, continue to **Glide Turn** around 4 remaining cones and tires, returning back into line. When player reaches the 3rd cone the next player goes. This allows 3 players from each team to be involved at the same time.

**Relay Race:** Perform drill as a race.

**Advanced:** Have players use blue pucks. When they get to the fourth cone they must pass the puck off the side boards back to themselves and continue through the course. Make sure players top hand wrist rolls back and forth and bottom hand grip is loose to guide the puck.



GLIDE TURNS



1 FOOT SNOW PLOW

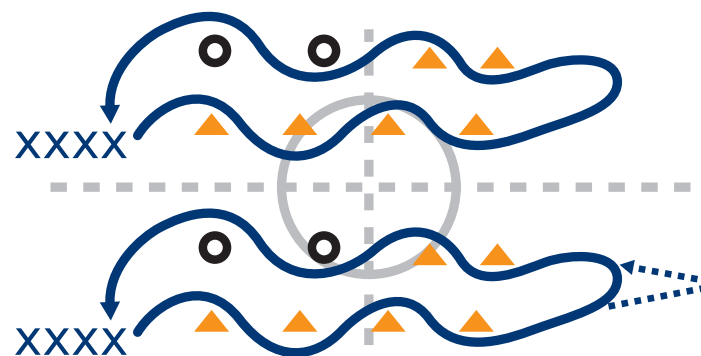



## GAME: SCATTER PUCK

10 MINUTES

All players have a blue puck. Divide the players into 2 teams. Each team must stay on their designated half of the ice. For 30 seconds players shoot blue pucks to the other team's side of the ice. Team with the least number of pucks on their side when time runs out wins. Repeat several times.

### Coaching Points:

- Emphasize keeping the hands away from the body and **Sweeping the Puck.**
- Start puck behind back skate with puck on the heel of the stick blade.
- Body weight is on the back leg.
- Head is up looking at the target, make eye contact with receiver.
- Puck is passed with a sweeping action of the arms.
- Pull with the top hand and push with the bottom hand.
- Transfer weight from the rear leg to the front leg.

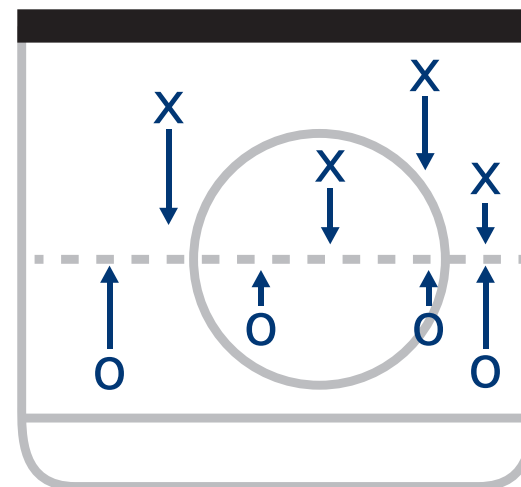
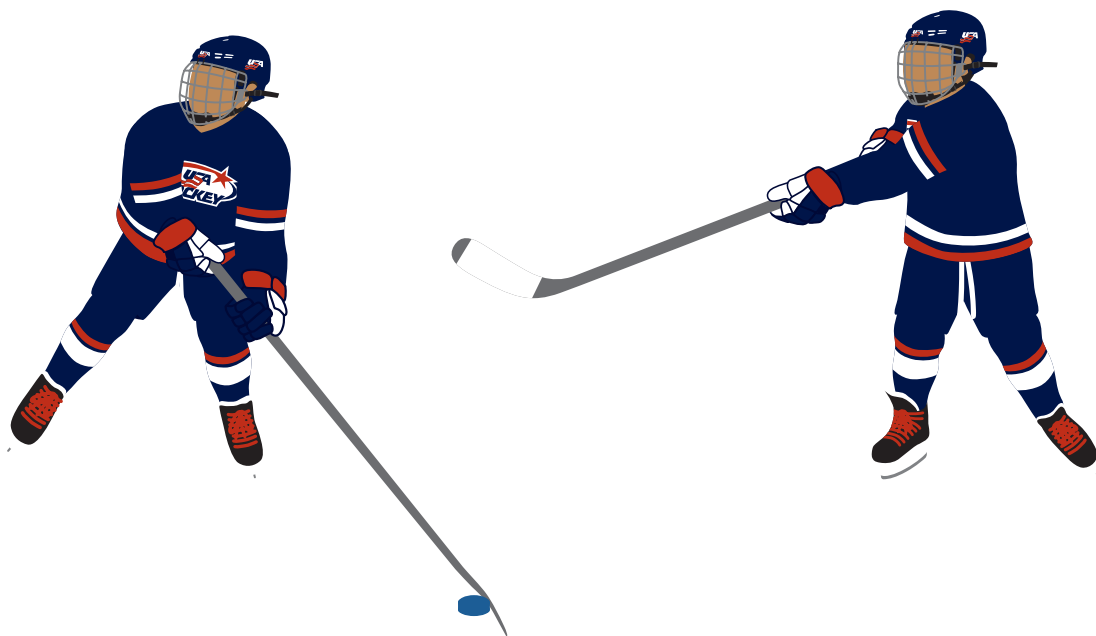



# GAME 1: BRITISH BULLDOG

10 MINUTES

*Players stand along the side boards. 1-3 Bulldogs (players or coaches) stand in the middle of the rink.*

Players along the boards try to skate to the far boards without being tagged by the **Bulldogs**. If tagged they become a **Bulldog** and remain in center to help tag players.

Play until you have a winner. Repeat.

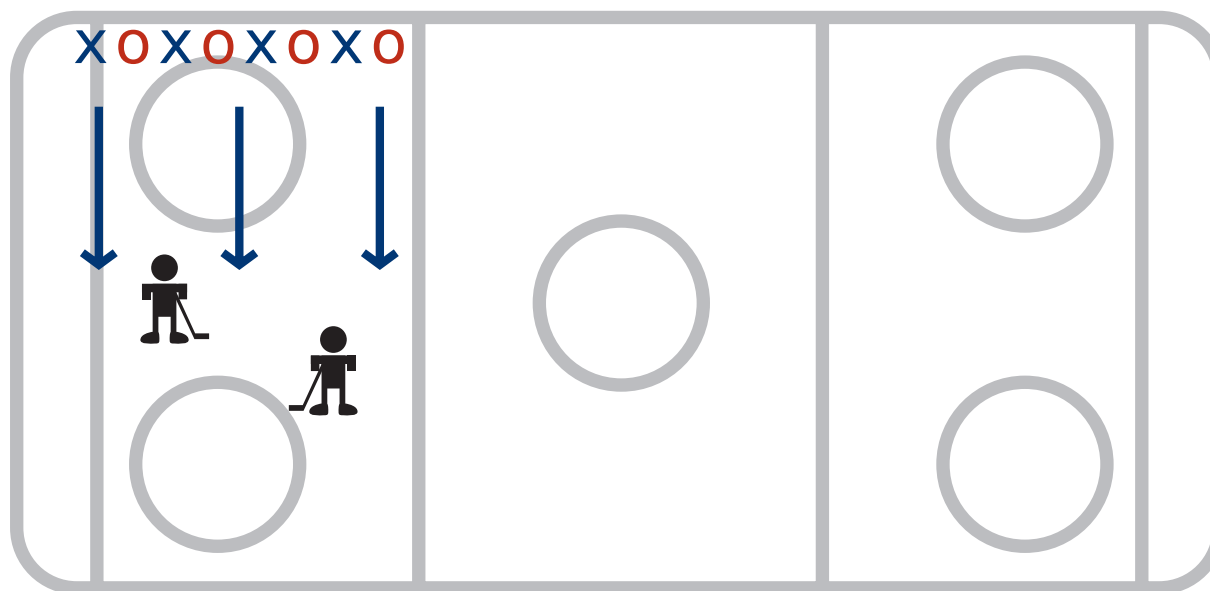



## GAME 2: FREEZE TAG

10 MINUTES

**Freeze Tag:** Coach **Tags** or selected players do the **Tagging** in designated area.

If tagged, player is **Frozen** and stands in the hockey ready position until they are set free.

The **Tagged** player is set free when another player skates a circle around them.

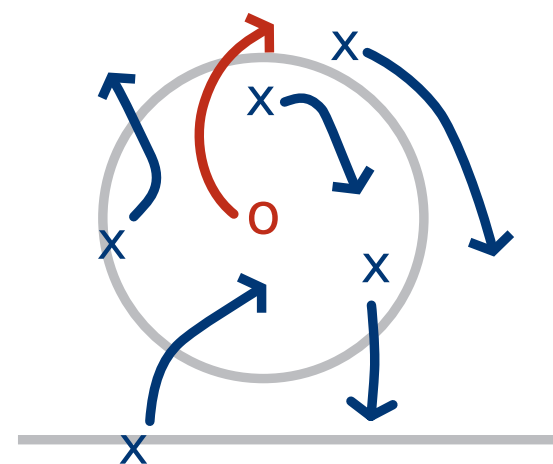



### GAME 3: COPS AND ROBBERS

10 MINUTES

Coaches are the **Cops** and players are the **Robbers**. Play tag on one third of the ice.  
To start game everyone stands in prison (middle circle).

Safe zones are the other 4 circles or neutral zone face off dots. No more than 2 players can be in a safe zone at a time.  
Players can only stay in one safe zone for 5 seconds. If tagged by a **Cop** you have to go to prison.  
Captured **Robbers** can be freed by another **Robber** tagging them.

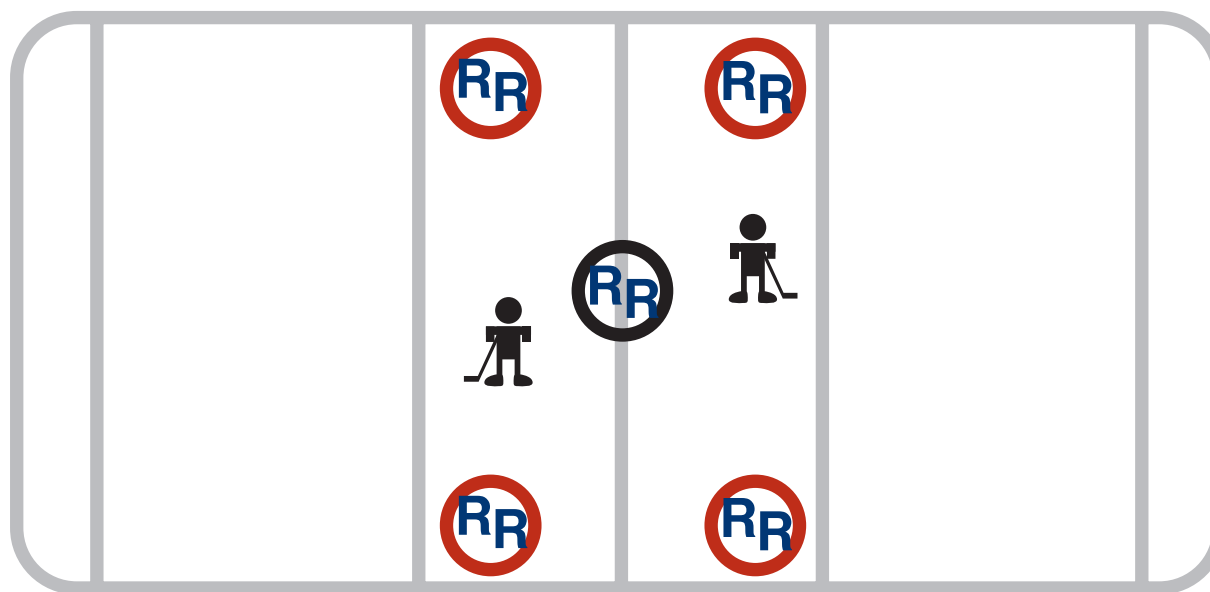

- PRISON
- SAFE ZONES
- ROBBERS
- COPS



GAME 4: RED LIGHT GREEN LIGHT

10 MINUTES

*Players start on side boards.*

Players skate towards center ice where the policeman (coach) is holding a red painted puck and a green painted puck. Coach can also use a crossing guard sign.

If coach holds up a red painted puck player must stop moving - working on **Snow Plow Stops**. Return to side boards and start again.

If player is caught moving on a **Red Light** they must return to start. First player to policeman (coach) is the winner.

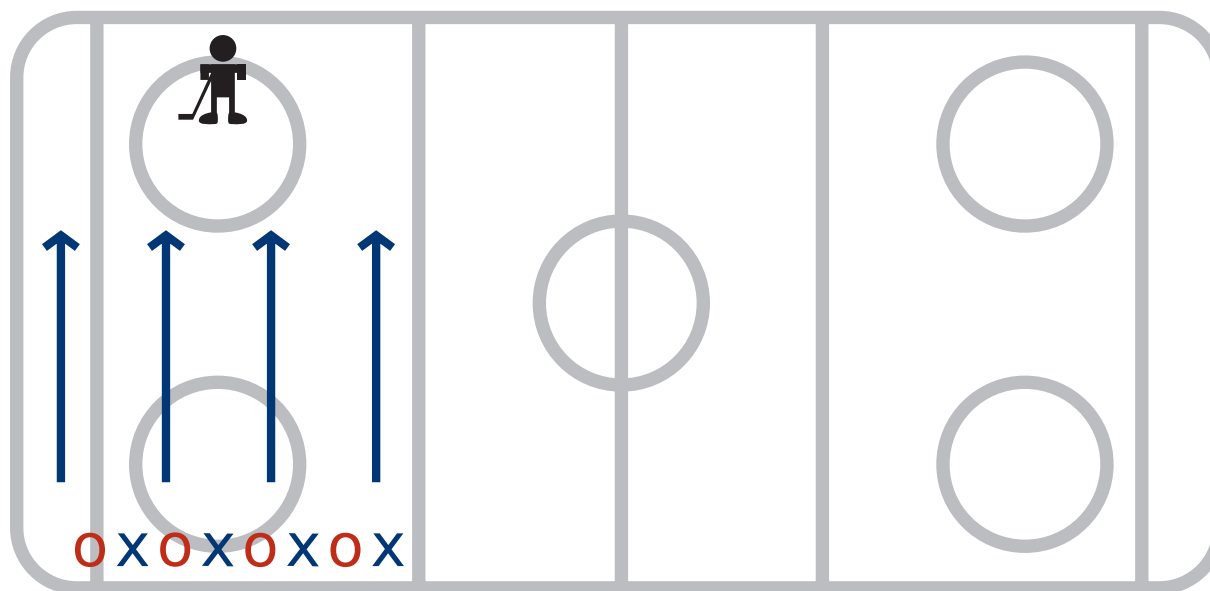



# GAME 5: KICK THE CAN

10 MINUTES

*Create 2 teams, and play without sticks.*

Use 2 soccer balls (cans) and play **3 v 3** or **4 v 4** with designated goals.  
Make sure kids bend their knees and use inside of foot while in kicking motion.

Rotate every 90 seconds.

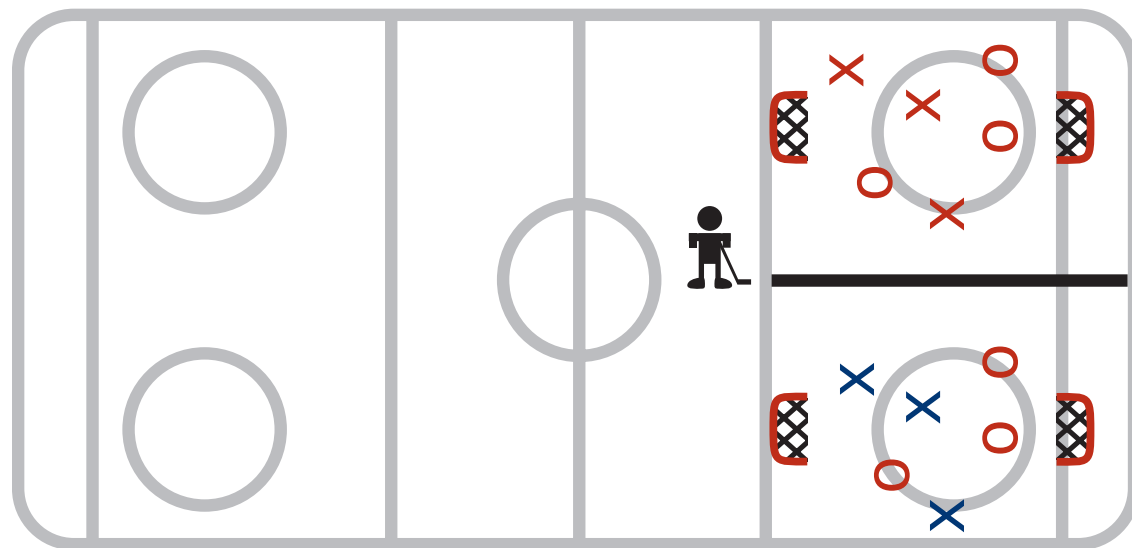



GAME 6: SCORE-0

10 MINUTES

All the pucks are scattered in the neutral zone. Divide players into 2 teams. Each team starts on their blue line. Use one third of ice surface to play **Score-0**.

On whistle each team tries to get as many pucks as they can onto the other team's nets. Players are allowed to steal pucks from the other team and out of their own net.

Team with the most goals after 3 minutes wins. Repeat.

